

Individually replaceable centralizer fins made from hardened steel

Controlled rotation allows jets time to evenly clean and clear lines

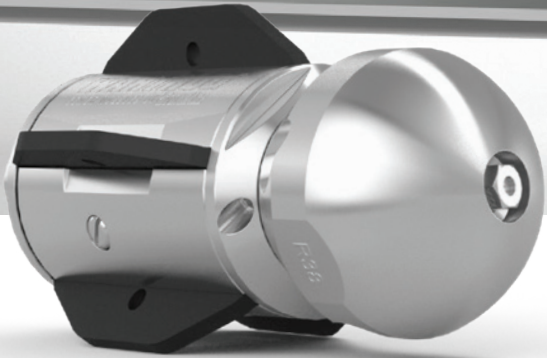

**JET ANGLES**

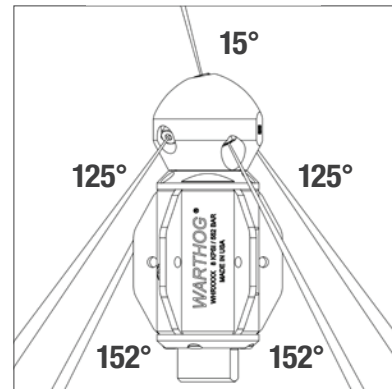

# WHR MAGNUM

**PIPE SIZE:** 6-18" (152-457 MM)

**INLET:** 1/2" NPT OR BSPP, 3/4" NPT OR BSPP

**BENEFITS:**

- Reduced operation expense and less downtime
- Effectively handles recycled water
- Carbide nozzles generate higher quality, longer lasting jets
- Independently replaceable centralizer fins
- Customizable rotation speed via viscous fluid options

MODEL/ INLET	PRESSURE RANGE		FLOW RANGE		HEAD	NOZZLE PORTS	JET TYPE	PORT PLUG	WEIGHTS		DIAMETER x LENGTH	
	PSI	BAR	GPM	LPM					LB	KG	IN.	MM
WHR-1/2	1200-8K	83-552	14-20	53-76	WHR 040-R38	5 X 1/8 NPT	CNP2	GP 025-P2SS	6.3	2.9	3.6 X 7.25	92 X 184
WHR-3/4	1200-5K	83-552	30-50	114-189	WHR 040-R18	5 X 1/8 NPT	CNP2	GP 025-P2SS	6.3	2.9	3.6 X 7.25	92 X 184
			20-40	76-151	WHR 040-R28							
			14-20	53-76	WHR 040-R38							