

Predominately used in large combination trucks with 1" (25 mm) hose

Controlled rotation allows jets time to evenly clean and clear lines

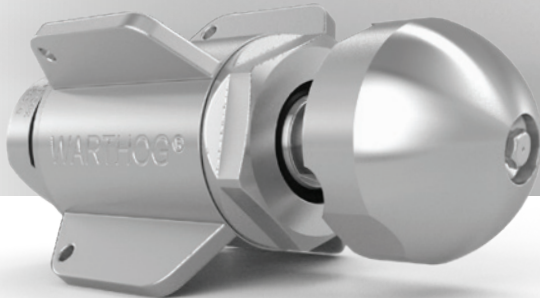

8-36" LINES

WG-PKG

PIPE SIZE: 8-36" (203-914 MM)

INLET: 1" NPT OR BSPP

BENEFITS:

- The industry's work-horse nozzle
- Controlled rotation allows jets to penetrate deeper through deposits to clean and clear pipes
- Descaling head available

JET ANGLES

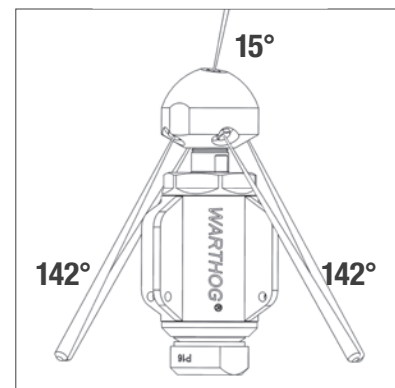

MODEL/ INLET	PRESSURE RANGE		FLOW RANGE		HEAD	NOZZLE PORTS	JET TYPE	PORT PLUG	WEIGHTS		DIAMETER x LENGTH	
	PSI	BAR	GPM	LPM					LB	KG	IN.	MM
WG-1	1200-5K	83-345	50-80	189-303	WG 040-R5	5 X 1/8 NPT	AP2	GP 025-P2SS	10.9	4.9	4.8 X 9.1	122 X 231
WGDS-1 DESCALER	1200-5K	83-345	50-80	189-303	WG 040-DS-R5	7 X 1/8 NPT	AP2	GP 025-P2SS	10.9	4.9	4.8 X 9.1	122 X 231